

トルク性能表 (実験値)

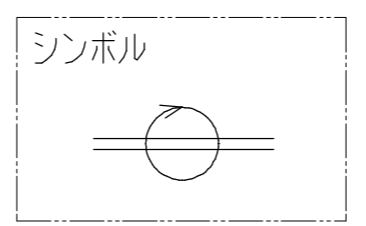

主仕様	
最高使用圧力	1 MPa
最大使用流量	20L/min.
使用流体	一般水道水 (MAX. 80℃)
最高使用回転数	400rpm △100rpm
材質	SUS304 (シールを除く)
重量	約 2kgG

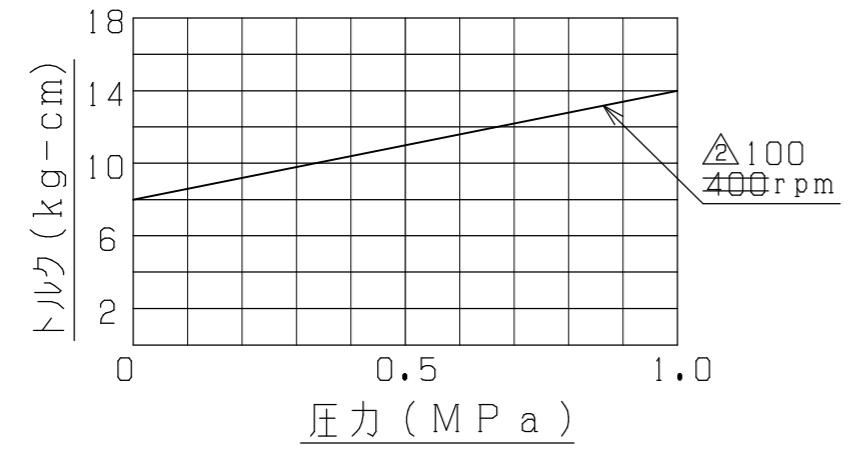
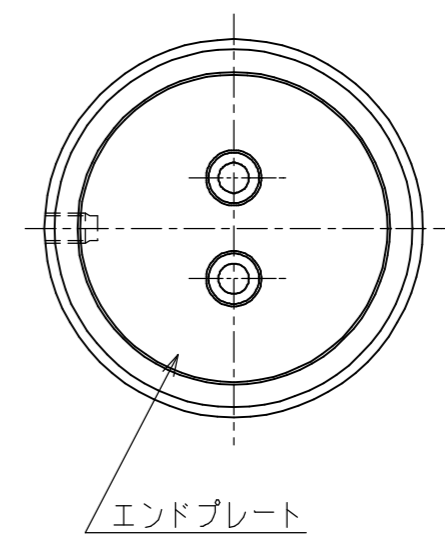
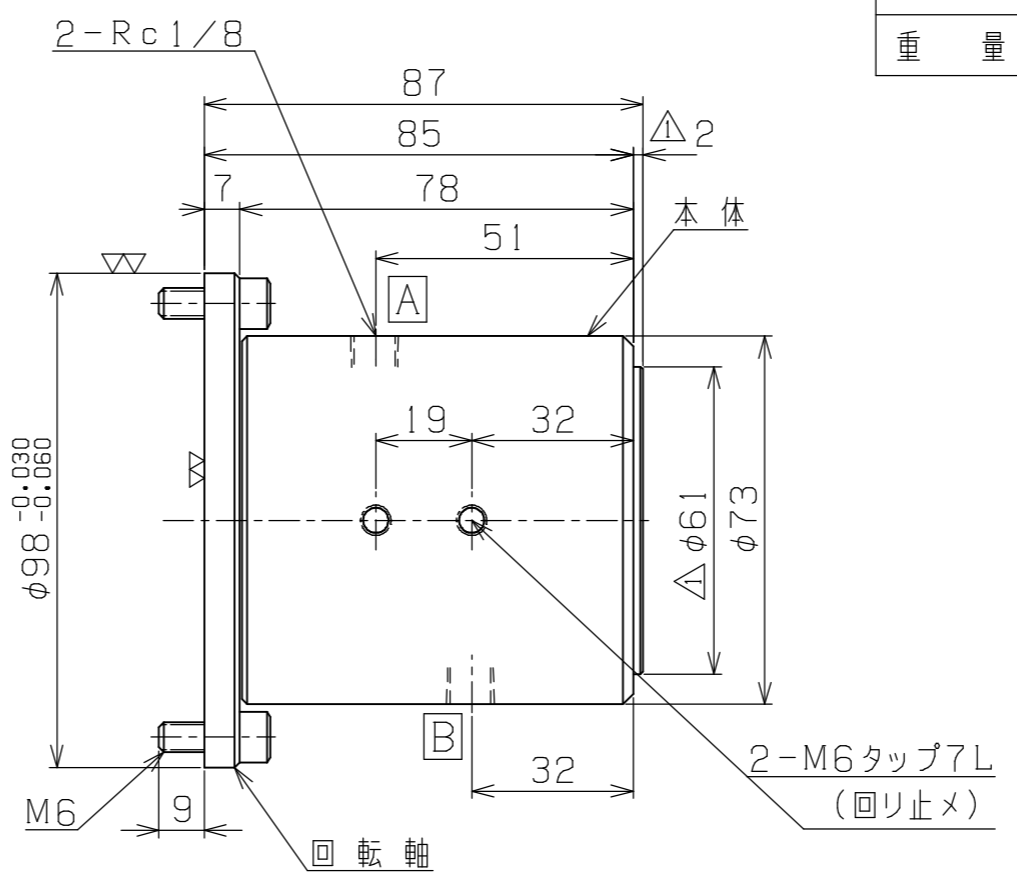
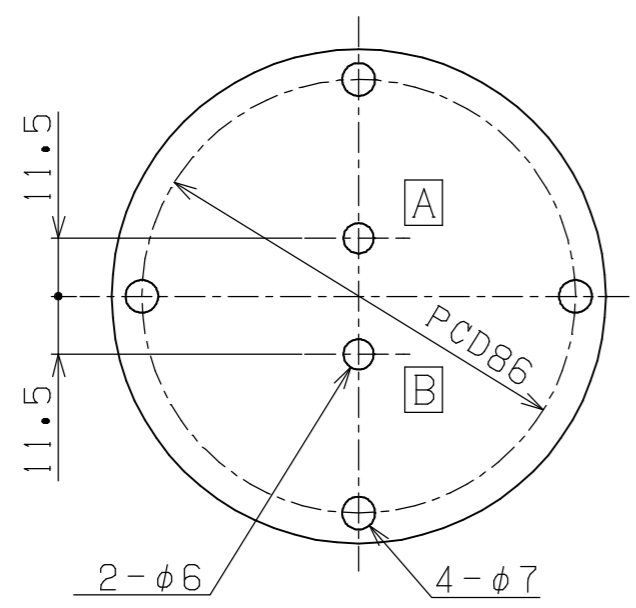

PLAN RECORD	基本仕上	MARK	PARTICULAR	QUAN	MATERIAL	SIZE	WEIGHT	REMARK
△H19-3-13共通化ニヨリ変更								
△H25-1-11 変更	寸法許容差	C H I E F			RJ2-1-20W-21			
	区分	許容差	H E A D			ROTARY JOINT		
	1 ~ 4	±0.1	CHECKED BY			DRAWING NO. A3-1639		
	5 ~ 16	±0.2	DRAWN BY <i>K. Saeki</i>					
	17 ~ 63	±0.3	DATE DRAWN					
	64 ~ 250	±0.5	SCALE 1/1.5			SAEKI ENGINEERING Co., LTD.		
	250~1000	±0.8						

記号
400S
100S
25S
6.3S
0.8S
▽▽▽